

WASTEWATER IN COMMERCIAL BUILDINGS

APPLICATION GUIDE

be
think
innovate

GRUNDFOS 

PREFACE

It is said that health and livelihood of people depends on the availability of clean and safe water. However, this is not the whole truth. Getting rid of the human wastewater in a safe, efficient and hygienic way is just as important as access to clean drinking water.

Imagine doing your daily shopping, walking through one of the many fast-growing cities during the seventeenth century. Explore the open-air markets and smell the aromas of fresh-baked bread and freshly picked fruit – and the stench of the nearby open sewage pools; the standard of sewer systems in those days. Nowadays much have changed and sewage is discharged of in closed pipe systems, which efficiently and hygienically carries the human excreta right from the water closet to the wastewater treatment plant.

However, climate changes is rapidly changing the world as we know it. Rainstorms with increased intensity, duration and frequency increases the risk of sewage backflows into buildings that are not provided with sufficient backflow protection. Sewage backflows occurs when the sewage systems is insufficient to handle increasing rainfalls or where cities are developed and populated in such a hurry that infrastructure capacity cannot keep up.

The solution to this requires bold political decisions and large investments in sewage infrastructure. However, political decisions, even in times of climate changes, are long time coming. Due to the increasing backflow risk and regardless of the present state of the sewage system infrastructure, all commercial building owners should safeguard their properties on their own. It should be just as natural as completing the building envelope in order to keep out wind and rain.

This application guide describes examples of the most efficient measures that can be taken in order to ensure that commercial buildings are kept safe against the intrusion of sewage backflow. It also describes best practices for calculating sewage water flow rate, rainwater flow rate and drainage water flow rate from commercial buildings. Also, it describes best practices for calculation and sizing of wastewater lifting stations as well as submersible pumping systems.

Jens Nørgaard

*Application Manager with
Grundfos Commercial
Building Services*



Climate change and water backflow	4
Other causes of wastewater backflow.....	6
Water backflow during a violent precipitation event.....	7
Measures against water backflow	10
Mechanical flap valves	10
Electrical flap valves.....	12
Pumping stations.....	13
Lifting stations.....	14
Wastewater applications.....	16
What is wastewater	16
Foul wastewater systems	18
Foul wastewater systems in a commercial building.....	18
Foul wastewater flow rate calculation.....	22
Rainwater systems	26
General.....	26
Rainwater run-off flow rate.....	28
Water drainage of buildings and structures	30
Why drain?	30
Pre-investigations.....	30
Classification of soil and groundwater conditions	32
Drain water flow rate.....	34
Wastewater pump sizing.....	36
Pump head, H_p	36
1.Static head, H_{geo}	38
2.Losses in valves and fittings, H_{VA}	40
3.Linear friction losses in discharge pipes, H_{VR}	40
Impeller types	56
S-tube impeller	56
Single-channel impeller	58
Vortex impeller	58
Grinders.....	59

CLIMATE CHANGE AND WATER BACKFLOW

Climate change is rapidly increasing the risk of flooding damage – and is only expected to accelerate in the future. This places new demands on the precautions we must take to avoid flooding. Higher precipitation intensities have already left many sewer systems with inadequate hydraulic capacities and many buildings with insufficient backflow protection.

Backflow and flooding problems range from relatively localised issues where water enters a few basements to major incidents where large sewer systems are not working.

The impact of backflow floods can be far reaching, including temporary relocation of people, risk of diseases, deterioration of water quality and damage to infrastructure and buildings.



Water backflow situation.

Many city sewer systems were designed and built decades ago and do not have sufficient capacity to deal with higher precipitation intensities. On mega scale, the solution is to increase the system's hydraulic capacity by increasing sewer main sizes, expanding sewer networks and/or erecting massive detention basins for the collection of surplus water. But as it requires heavy investment, bold political decisions, careful planning and execution, this is easier said than done. Instead, commercial building owners must ensure that water backflows are stopped before buildings and interior are damaged.

In most countries backwater protection is liable according to the local legislation. Safeguarding buildings against backwater flooding is an essential part of the building process and the responsibility for doing so lies solely with the building owner and the building design team. The wastewater utility company and/or municipality do not normally bear any liability for damages.

Other causes of wastewater backflow

Higher precipitation intensity is not the only cause of sewage backflow. Sewers can be flooded for a number of reasons:

- Blocked sewers, e.g. tree roots.
- Collapsed sewers.
- Equipment failure, e.g. pumping station failure .
- Fat and grease mixes with other sewer debris and solidifies to form a very hard coating inside the sewer pipe. This build-up of fat and grease causes a narrowing of the pipe and restricts flow, or in some cases forms a complete blockage.
- Paper and cloth, including disposable diapers can expand in water to block the sewer pipe.
- Roadway sediments and silt settle in the pipe due to low sewer flows. In some pipe lines, the normal self-cleaning flow of wastewater is insufficient to maintain free flow and can cause flow-restricting build-up.



Example of fat, grease and debris build-up in a large sewage pipe.



Rainstorm intensities are increasing these years.

Water backflow during a violent precipitation event

The water overflow level in sewer systems is determined by several factors.

Precipitation characteristics:

- Precipitation intensity in [l/s/ha]. Precipitation intensity describes the precipitation rate per hectare. As precipitation intensity increases, so does water backflow in the sewage main.
- Precipitation duration [min]. Precipitation duration describes the rainfall time in minutes. High intensity rainfalls are usually brief, and vice versa.
- Precipitation frequency. Precipitation frequency describes how often rainfall will occur.

Sewer system characteristics:

- Water run-off coefficient [-]. The run-off coefficient describes the share of the precipitated water that will have to be collected in a sewer system.
- Sewer pipe sizes [m]. The sewer pipe size is proportional to the hydraulic capacity of a given sewer pipe.
- Pipe gradient [%]. The pipe gradient influences the pipe's hydraulic capacity. The higher the gradient, the higher flow rate capacity.
- Detention basin volumes [m³]. Detention basins serve as water flow restrictors that shave off rainwater peaks. Sewer systems with many detention basins can cope with higher precipitation intensities and durations.

In order to reduce costs to excavation, sewer pipes and retention basins, practically all rainwater-carrying sewer systems are sized for a certain water backflow level. The maximum backflow level is somewhere between the sewer and the terrain (street). During violent precipitation events, the utility company monitors backflow levels and use the data to draw up backflow level maps. These are available on request. However, climate change is expected to accelerate in the future. These changes will occur over long periods with significant, short-term random variation - and no single event will signal the arrival of “climate change”. Also, current climate models demonstrate limited skill at predicting future precipitation on the local and regional scale needed by building investors and consultants. This leads to the conclusion that consultants sizing and planning building sewer systems should play it safe rather than react to observed events and overflow level registration. The highest possible sewer backflow level is ground surface and hence it is recommended always to safeguard buildings to that level.

What to do?

- Plan ahead.
- Secure buildings against water backflow.
- Consulting engineers and building owners are responsible.



Backflow map showing the result of an extreme rainstorm incident. The blue areas are flooded with water after a high-intensity rainstorm event.



*Water backflow event where an unprotected basement is flooded.
In this situation, the building must be evacuated as the sanitary system is out of use.*

MEASURES AGAINST WATER BACK-FLOW

Mechanical flap valves

The mechanical flap valve – supplied with a floater that shuts off the pipe in case of water backflow – is backflow prevention in its most simple form. The water lifts the floater and the flap closes the pipe.

Use of backflow valves is normally only recommended when:

- there is downward slope away from the valve to sewer system.
- protected rooms are used as, e.g. storage room - living rooms and similar is not allowed.
- it is possible to abandon the usage of the sanitary appliances in the building.
- no material assets are exposed.
- the user group is small.

Local regulations may differ.

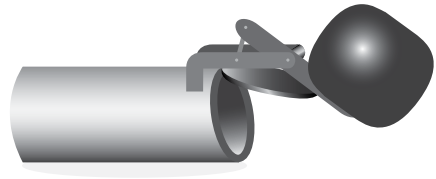

Example of a mechanical flap valve. Supplied with a floater that shuts off the pipe in case of water backflow.

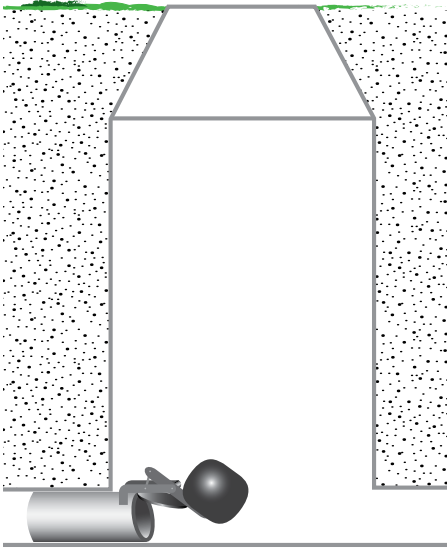

Mechanical flap valve placed in an inspection well.

Advantages:

- Simple and well-known principle.
- Cheap solution.

Disadvantages:

- In case of water backflow, use of the building's sanitary system is not possible since sewage water cannot pass the closed valve. The (typical) lack of a valve alarm signal means that users will carry on using the building's sanitary system and cause a basement flooding.
- Has to be inspected and cleansed regularly.
- Sensitive to sand and solid objects in the water. The valve will not close properly if an object is stuck between the flap and the pipe. In this case, water will seep back into the basement.
- Backflow alarms can normally not be connected.
- Should only be used to protect secondary rooms, where no valuable items or equipment are located.

Electrical flap valves

The electrical flap valve is usually supplied with two closing flaps. One flap is electrically controlled by a sensor electrode that registers water backflow, while the other flap is manually operated for maintenance purposes.

Advantages:

- Provided with an alarm system that notifies maintenance staff in water backflow situations.
- Installed indoor for easy access and maintenance.

Disadvantages:

- Has to be inspected and cleansed regularly.
- Sensitive to fat and grease residue on flaps and sensor electrode.
- Sensitive to sand and solid objects in the water. The valve will not close properly if an object is stuck between the flap and the pipe. In this case, water will seep back into the basement.
- In water backflow situations, use of the building's sanitary system is not possible, since sewage water cannot pass the closed valve.
- Should only be used to protect secondary rooms, where no valuable items or equipment are located.

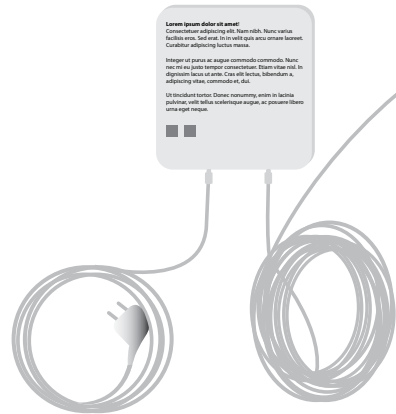

Electrical flap valve.

Pumping stations

A pumping station can be used as an antiflooding device instead of flap valves. In order to obtain anti flooding safety, the highest geometric point of the pressure pipe should be located above the highest flooding level, i.e. street level.

Advantages:

- Offers maximum backflow and flooding safety since the highest geometric point of the pressure pipe is located above the highest possible flooding level. Can be used for the protection of electrical equipment, process equipment and other high value equipment.
- The pressure pipe is fitted with a non-return valve, which offers additional back flow and flooding safety.
- In water backflow situations, use of the building's sanitary system is allowed. Sewage water from the building is pumped into the sewer main even if it is flooded.
- Complies with local legislation.
- Not sensitive to solids in the water.

Disadvantages:

- Has to be located outside the building.

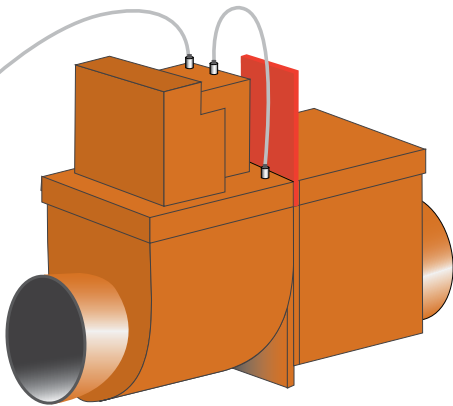

Lifting stations

A lifting station offers the ultimate anti-flooding safety. In order to obtain maximum anti-flooding safety the highest geometric point of the pressure pipe should be located above the highest possible flooding level, which is usually street level.

Advantages:

- Offers maximum backflow and flooding safety, since the highest geometric point of the pressure pipe is located above the highest possible flooding level. Can be used for the protection of electrical equipment, process equipment and other high value equipment.
- The pressure pipe is fitted with a non-return valve, which offers additional backflow and flooding safety.
- In water backflow situations, unlimited use of the building's sanitary system is allowed. Building sewage water is pumped into the sewer main even if it is flooded.
- Location in basement etc. normally ensures easy service and maintenance.
- Can be installed in rainwater systems if required.
- Not sensitive to solid objects in the water.

Disadvantages:

- Space requirements in basement.

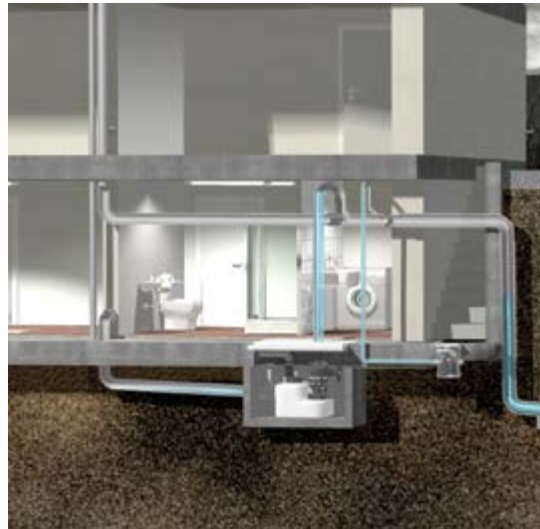

Water backflow event during a heavy rainfall. Here the water does not enter the building above the highest backflow level (street level) and is furthermore supplied to the sewer main.

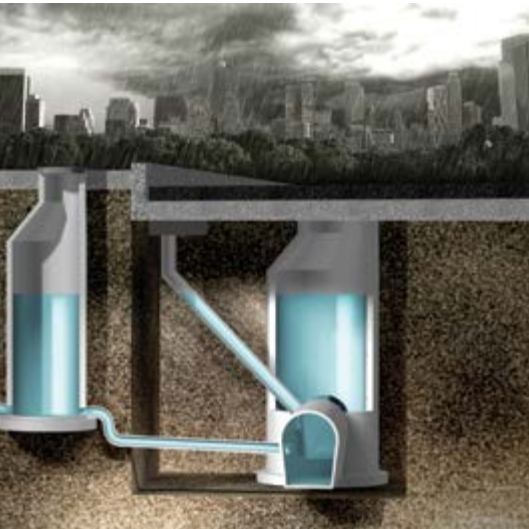

...ter the building because the lifting station's pressure pipe is looped
...d with a non-return valve.

WASTEWATER APPLICATIONS

What is wastewater?

Wastewater is the common designation for water that in any way has been affected in quality by human influence, and which is transported through a combined or separate sewer system.

Wastewater contains a broad spectrum of waste of organic or inorganic origin, discharged from different sources. These sources can be domestic residences, commercial properties, industry, agriculture as well as surface run-off and infiltrated water in the sewer system.

The sources are commonly divided into categories:

- Foul wastewater: A common designation for black and grey wastewater. Black wastewater is discharged from WCs, urinals and bidets, while grey wastewater is less polluted and discharged from showers, baths, wash basins, sinks and floor gullies.
- Rain water: Water from precipitation which has not seeped into the ground. Rain water is discharged to the drain or sewer system directly from the ground or from exterior building surfaces.
- Drainage water: Water from basement drains around and below buildings, drive way drains, garden drains and land drainage.



Parking garage.



Wastewater inspection in a large sewage main pipe.



- Parking areas: Wastewater originating from parking garages consists primarily of snow melt and water from carwash areas. Waste water from parking garages often contains soap, oil, petrol, salt and sand residue. Before such water is pumped to the sewer main, it should be treated in an oil/petrol separator and in a sand sedimentation trap. Pipes carrying water from parking areas must be fitted with oil-resistant seals and pumps must be EX-approved in order to avoid explosions.

FOUL WASTEWATER SYSTEMS

Foul wastewater is the common designation for black and grey wastewater.

- Black wastewater describes wastewater that contains faecal matter and urine. Furthermore, it may contain fibres, textiles and other large solids up to approx. 100 mm. If a grinder is not used to shred the large particles into smaller fragments, it is important that both sewage pipes and pressure pipes are sized correctly in order to avoid clogging.
- Wastewater without faecal matter or urine is referred to as grey water. Grey water comprises 50-80% of residential wastewater and may contain solids up to approx. 35 mm.

Foul wastewater systems in a commercial building

A building's wastewater flow rate is calculated by using the flow rates of the wastewater discharge units (toilets, floor gullies etc.) connected to the sewer system, by the number of discharge units and by their frequency of use.

A wastewater system within a building may be designed in several ways according to national and/or local regulations and practices. EN standard 12056-2 offers four different system types with distinctive characteristics.



Sewage main pipes below the streets of London.

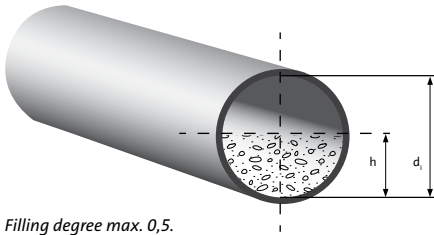

Filling degree max. 0,5.

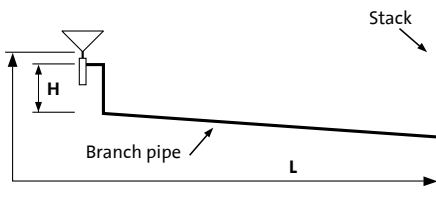

Sewage pipes within a building

System type I:

Single discharge stack system with partly filled branch pipes for connection to sanitary appliances. The partly filled branch discharge pipes are designed with a filling degree of max. 0,5 and are connected to a single discharge stack.

Characteristics and limitations for ventilated pipes, type I:

- Maximum length, $L = 10$ m
- Maximum drop, $H = 3$ m
- Minimum gradient 0,5 %
- Unlimited number of 90° bends

Characteristics and limitations for unventilated pipes, type I:

- Maximum length, $L = 4$ m
- Maximum drop, $H = 3$ m
- Minimum gradient 1 %
- No more than three 90° bends

System type II :

Single discharge stack system with partly filled branch pipes for connection to sanitary appliances. The partly filled branch discharge pipes are designed with a filling degree of max. 0,7 and are connected to a single discharge stack. In general, a type II system is characterised by having smaller pipe sizes and a larger minimum gradient than a type I system.

System type II is typically preferred in commercial buildings.

Limitations for ventilated pipes, type II:

- Unlimited length, L
- Maximum drop, $H = 3$ m
- Minimum gradient 1,5 %
- Unlimited number of 90° bends

Limitations for unventilated pipes, type II:

- Maximum length, $L = 10$ m
- Maximum drop, $H = 3/6$ m depending on size
- Minimum gradient 1,5 %
- No more than one 90° bend

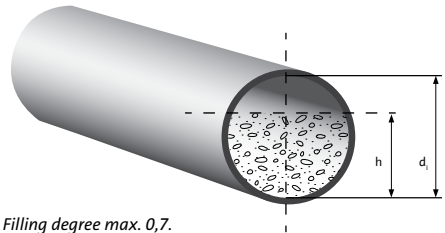

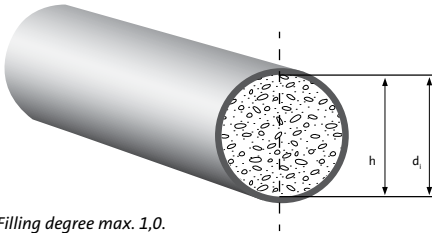

Filling degree max. 1,0.

System type III :

Single discharge stack system with filled branch pipes for connection to sanitary appliances. The filled branch discharge pipes are designed with a filling degree of 1,0 and are connected to a single discharge stack.

Type III limitations for both ventilated and unventilated pipes are numerous. For specification according to appliance type, see EN 12056-2.

System IV :

Here, systems of type I, II or III are divided into separate discharge stack systems for black wastewater (WCs and urinals) and for grey wastewater. If grey water in the building is collected and cleansed for reuse, the system will have to be designed according to type IV.

Foul wastewater flow rate calculation

The amount of and the flow rate from sanitary appliances is determined very straight forwardly. EN 12056-2 offers a table with typical flow rate values per appliance. Simultaneously discharge from appliances has to be predicted by means of statistical data, based on the building type, occupancy and likely usage pattern.

EN 12056-2 provides the following formula for the calculation of real or expected flow rates in whole and partial sewage system where only domestic sanitary appliances are connected.

$$Q_{ww} = K \sqrt{\sum DU} \quad \text{where}$$

Q_{ww} = Wastewater flow rate (l/s)

K = Frequency factor

DU = Sum of water flow rate discharge units (l/s)

The frequency factor K is determined by consulting the table below. If the sewage system serves a multi-purpose building with varying occupation patterns, each of these areas will have to be calculated separately with the appropriate factor, K . The resulting flow values are then added together.

Appliance / discharge unit	System I DU l/s
Wash basin, bidet	0,5
Shower without plug	0,6
Shower with plug	0,8
Single urinal with cistern	0,8
Urinal with flushing valve	0,5
Slab urinal	0,2*
Bath	0,8
Kitchen sink	0,8
Dishwasher (household)	0,8
Washing machine up to 6 kg	0,8
Washing machine up to 12 kg	1,5
WC with 4,0 l cistern	**
WC with 6,0 l cistern	2,0
WC with 7,5 l cistern	2,0
WC with 9,0 l cistern	2,5
Floor gully DN 50	0,8
Floor gully DN 70	1,5
Floor gully DN 100	2,0
* per person	
** not permitted	
*** depending upon type (valid for WC's with siphon)	
- not used or no data	

Water flow rates for various types of discharge units (DU) according to EN 12056-2

Usage of appliances
Intermittent use eg. in dwelling, guesthouse, office
Frequent use eg. in hospital, school, restaurant, hotel
Congested use eg. in toilets and/or showers open to public
Special use eg. laboratory

Frequency factor according to the building type and use. According to EN 12056-2

System II DU l/s	System III DU l/s	System IV DU l/s
0,3	0,3	0,3
0,4	0,4	0,4
0,5	1,3	0,5
0,5	0,4	0,5
0,3	-	0,3
0,2*	0,2*	0,2*
0,6	1,3	0,5
0,6	1,3	0,5
0,6	0,2	0,5
0,6	0,6	0,5
1,2	1,2	1,0
1,8	**	**
1,8	1,2 to 1,7***	2,0
1,8	1,4 to 1,8***	2,0
2,0	1,6 to 2,0***	2,5
0,9	-	0,6
0,9	-	1,0
1,2	-	1,3

non flush cistern only)

ing to EN 12056-2.

	K
	0,5
el	0,7
p public	1,0
	1,2

ing to EN 12056-2.

The total flow rate Q_{tot} , i.e. the design flow rate, is calculated from:

$$Q_{tot} = Q_{ww} + Q_c + Q_p \quad \text{where}$$

Q_{tot} = Design flow rate (l/s)

Q_{ww} = Wastewater flow rate (l/s)

Q_c = Continuous flow rate (l/s)

Q_p = Pumped water flow rate (l/s)

Q_{tot} is the total flow rate from continuous, non-continuous and local pumping stations. Water flows from continuous appliances and local pump stations, connected to the system, should not be reduced with a frequency factor.

Branch pipes, stack pipes and lifting/pumping stations should be sized on basis on the maximum flow rate Q_{max} , which is the larger of:

1. Q_{ww} (l/s)
2. Q_{tot} (l/s)
3. The highest flow rate of any appliance connected to the system. (DU-table) (l/s)

EXAMPLE: CALCULATION OF WASTEWATER FLOW RATE, Q_{tot}

A hotel's sewage system will have to be connected to an outside building sewage main. Guest rooms and the restaurant are located above street level, causing wastewater from these facilities to gravitate to the sewer main in the nearby street. Wastewater from all other facilities will have to be pumped to the sewer main, as they are located in the building's basement.

In this building, there are no sanitary installations supplying a continuous flow rate Q and there are other pumping stations. Hence, Q_p is not relevant. In this building the design flow rate Q_{tot} will be equal to Q_{ww} .

$$Q_{ww} = K\sqrt{\sum DU} = 0,7\sqrt{28,9} = 3,76 \text{ l/s}$$

$$Q_{tot} = Q_{ww} + Q_c + Q_p = 3,76 + 0 + 0 = 3,76 \text{ l/s}$$

The required pump must be able to handle a flow rate of at least 3,76 l/s during operation.

Discharge unit (DU), System II	Amount pcs.
Kitchen & staff facilities	
Dishwasher, large	1
Kitchen sinks	4
Floor gullies, DN 70	6
WC's	4
Showers	4
Guest rest room facilities	
WC's	5
Urinals	3
Wash basins	4
Sum, DU	

Usage of appliances
Intermittent use eg. in dwelling, guesthouse, of
Frequent use eg. in hospital, school, restaurant,
Congested use eg. in toilets and/or showers open
Special use eg. laboratory

Water flow-rate, l/s	Total water flow-rate, l/s
1,2	1,2
0,6	2,4
0,9	5,4
1,8	7,2
0,4	1,6
1,8	9,0
0,3	0,9
0,3	1,2
28,9	

	<i>K</i>
Office	0,5
Hotel	0,7
Open to public	1,0
	1,2

RAINWATER SYSTEMS

Rainwater run-off originates from precipitation or snowmelt from:

- Building facades
- Building rooftops
- Balconies
- Drives and sidewalks
- Grass lawns

Rainwater may contain sand, stones, leaves and other dirt with solids up to approx. 50 mm. Rainwater may hold various pollutants as well. When run-off flows towards the sewer system it can pick up different road contaminants, such as petroleum, tyre waste, metal species, pesticides or fertilisers.

General

In most commercial buildings, rainwater will have to be discharged to a recipient. The need for pumping capacity will depend on how much of the naturally occurring rainwater can be taken away by gravity or be absorbed underground through “soak away’s”. Excess rainwater pumping will have to occur through separate drainage systems to the sewer mains in order to avoid potential flooding of the main sewer system. Discharge from surface water systems should not be connected to a combined system unless it has been designed to accept both foul water and rainwater. If it has, it is important to separate foul water and rainwater up until the connection point to the combined sewer system.

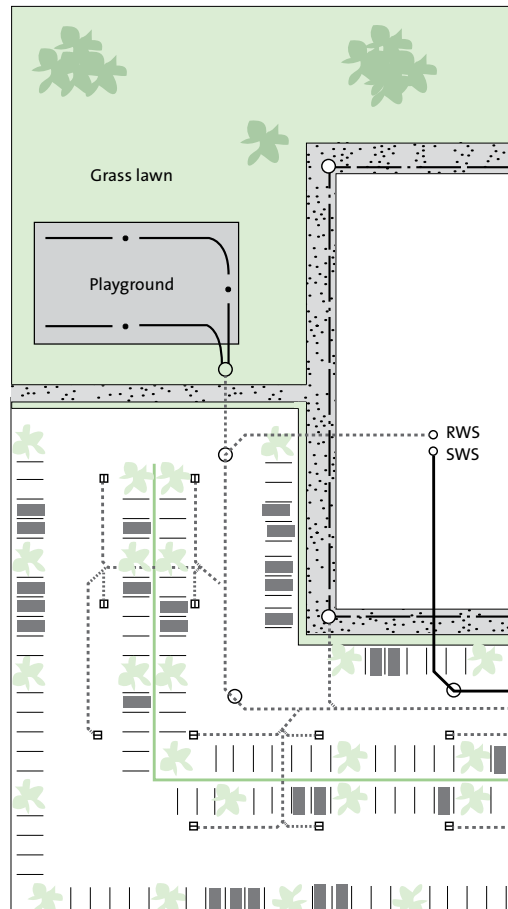

Example of a combined drainage system servicing a commercial building

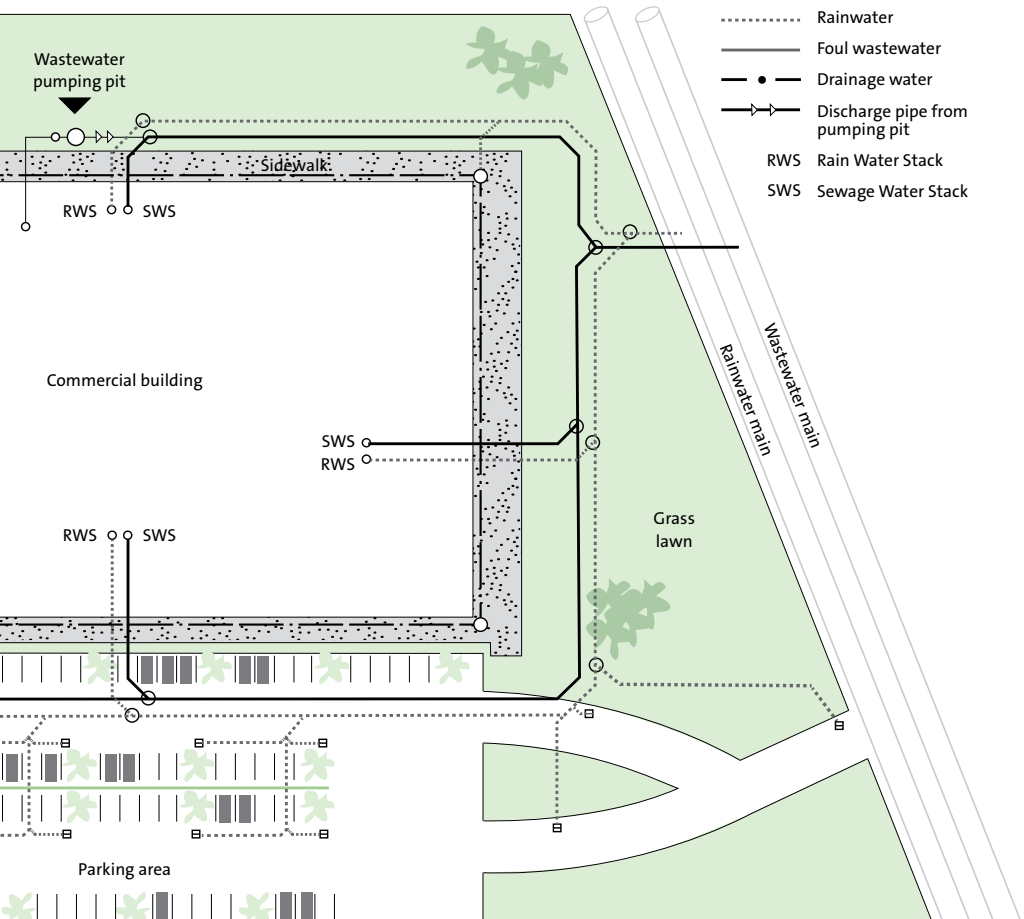

ding.

Rainwater run-off flow rate

Sizing and design of rainwater systems requires an assessment of the likely worst-case rainfall intensity, frequency and duration on buildings and the site.

The following tabulated values of typical rainwater intensities can be used in the planning of rainwater removal systems. n is the probability of a rainfall event with the same or higher intensity than the given intensity, i . If n is $\frac{1}{2}$, a rainfall of the given intensity or higher is likely to occur once every two years. The table shown is based on many years of rainfall registration in Northern Europe. All intensities are based on a rainfall duration of 10 min.

Note:

Since rainfall events around the world may vary in intensity, duration and occurrence, rainwater systems should always be sized in accordance with national guidelines and legislation.

Run-off coefficient, c

The amount of run-off is dependent on the surface permeability and describes the amount of rainwater that appears as run-off in relation to the total rainwater amount.

$$c = \frac{\text{run-off amount}}{\text{rainfall amount}}$$

Examples of run-off coefficients, c according to surface type:

Unimproved areas	0,10 – 0,30
Residential areas	0,30 – 0,75
Lawns	0,05 – 0,35
Asphalt streets	0,70 – 0,95
Concrete streets	0,80 – 0,95
Brick streets	0,70 – 0,85
Playgrounds	0,20 – 0,35
Drives and walks	0,75 – 0,85
Roofs and facades	0,75 – 0,95

Application	n	Rainwater i l/sm ² (l/sha)
Separate systems: Where there is only a risk of inconvenience, e.g. flooding outside building	1	0,011 (110)
Common systems: Where there is only a risk of inconvenience, e.g. smell. Flooding is not acceptable	1	0,011 (110)
Where there is a risk of minor damage to buildings, furniture, machines or equipment. Resumption of normal service should be possible with ordinary cleaning and short-term drying.	1/2	0,014 (140)
Where there is a risk of severe damage to buildings, machines or equipment	1/10	0,023 (230)
Where there is a risk of accidents or health hazards to animals or human beings	~ 1	Maximum expected rainwater intensity to be used

The total rainwater flow rate Q_r is calculated from:

$$Q_r = A \cdot i \cdot c \quad \text{where}$$

Q_r = Design flow rate (l/s)

A = Run-off area (m²)

i = Rainfall intensity (l/sm²)

c = Run-off coefficient (-)

EXAMPLE: CALCULATION OF RAINWATER RUN-OFF RATE

A rainwater system for a commercial building has to be designed. The building's roof is 460 m² and the facade area 3.000 m². The catchment is determined by reviewing the building(s) surface run-off areas and the site on which the property stands. Run-off coefficients are used to reduce the quantity, depending on the likely surface absorption:

Catchment areas

Horizontal area (roof(s)):		460 m ²
Vertical area (facade on one side):	$3.000 \text{ m}^2 \cdot 1/3 =$	1.000 m ²
Playground, gravel:		800 m ²
Driveway, asphalt:		500 m ²
Lawn:		1.500 m ²

Rainwater intensity of 140 l/s/ha is used to prevent risk of minor building damage.

Total flow, $Q_r = A \cdot i \cdot c$

Roof	$460 \text{ m}^2 \cdot 0.014 \text{ l/sm}^2 \cdot 0,95$	= 6,1 l/s
Facade	$1.000 \text{ m}^2 \cdot 0,014 \text{ l/sm}^2 \cdot 0,95$	= 13,3 l/s
Playground	$800 \text{ m}^2 \cdot 0.014 \text{ l/sm}^2 \cdot 0,35$	= 3,9 l/s
Driveway	$500 \text{ m}^2 \cdot 0.014 \text{ l/sm}^2 \cdot 0,85$	= 6,0 l/s
Lawn	$1.500 \text{ m}^2 \cdot 0,014 \text{ l/sm}^2 \cdot 0,35$	= 7,4 l/s

Rainwater flow rate, Q_r = 36,7 l/s

WATER DRAINAGE OF BUILDINGS AND STRUCTURES

Why drain?

Water drainage is applied to buildings and structures for a variety of purposes:

- Foundation draining to remove water that may damage buildings and interior: Water penetration might cause corrosion of steel reinforcements, and it can cause mould and fungus in the building.
- Groundwater lowering in order to reduce or stabilize groundwater pressure: Reduced pressure on slabs and basement walls founded below groundwater level can prevent overall structural failure. Too high hydrostatic pressure can lift the whole building.
- Consolidation of soil. Water-saturated soil and backfill can be unstable and unsuited for construction. Water draining can improve the strength of the material.

Pre-investigations

Existing soil, future soil and groundwater conditions should be investigated thoroughly before construction. At minimum, the following parameters should be investigated:

- Soil conditions: Soil classification (clay, sand, silt etc.) and soil layer build-up, strength, permeability and capillarity.



Drain pipe embedded in a gravel trench.

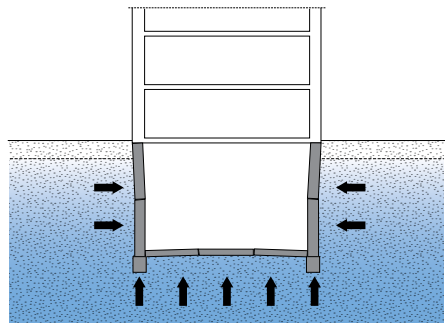

Building exposed to hydrostatic water pressure

- Groundwater level: Measurement of water table in primary and secondary aquifers should be conducted and seasonal variations predicted.
- Impact on soil and surroundings: Installation of drain systems will often impact the primary and secondary groundwater table, which can lead to terrain settlements and settlement of constructions. A reduced groundwater table will reduce soil saturation and may provoke decay in wooden constructions.
- Chemistry: Groundwater chemistry should be evaluated or analysed in relation to precipitation of unwanted limestone or iron ore. Precipitation of these two components can clog a draining system, while aggressive water can attack drainage system and constructions.

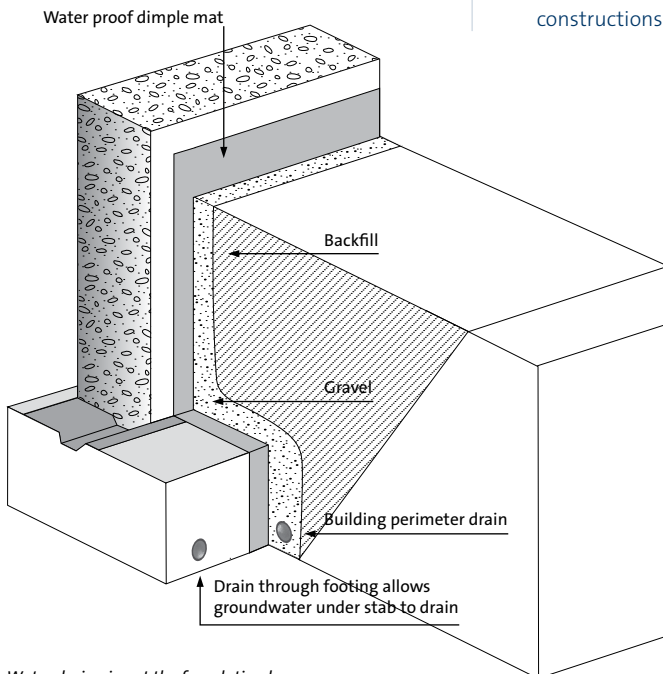

Water drain pipe at the foundation base

Classification of soil and groundwater conditions

In order to determine whether a building or structure should be drained or not, and in order to calculate drainage water flows, ground-water and soil conditions basically should be categorized.

Note:

This chapter's drainage procedures are based on Danish standard DS436. Drainage of buildings and structures should always be based on local legislation and guidelines.

Note:

Artesian water is not discussed in this guide. Artesian water can occur, where impermeable soils are found on top of permeable layers saturated with water.

Soil type	Water velocity	Coefficiency of permeability, k (m/s)
•Clean gravel	Rapid	10^{-1}
•Clean sands •Clean sands and gravel mixtures		10^{-2}
•Very fine sands •Organic and in-organic silts •Mixtures of sand, silt and clay •Stratified deposits, etc.	Moderate	10^{-3} 10^{-4} 10^{-5} 10^{-6} 10^{-7}
•Stratified soils, eg. homogeneous clays below the weathering zone	Slow	10^{-8} 10^{-9} 10^{-10} 10^{-11}

Coefficients of permeability, depending on soil type

Class 1:

Sandy or other permeable soils with groundwater table below drainage level. Drainage is not required. Seasonal variations in groundwater table are not predicted to increase to drainage level. Storm water or other surface water will soak vertically to the groundwater table.

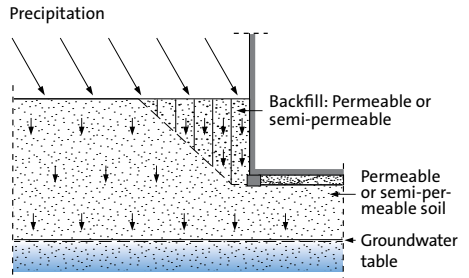

Draining in sandy or very permeable soils where the groundwater table is below drainage level

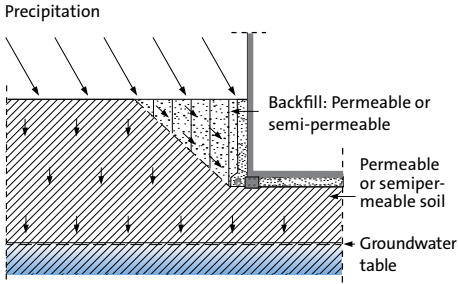

Draining in low-permeability soils where the groundwater table is below drainage level

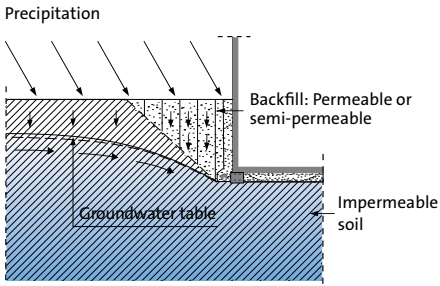

Draining in low-permeability soils with groundwater table higher than drainage level

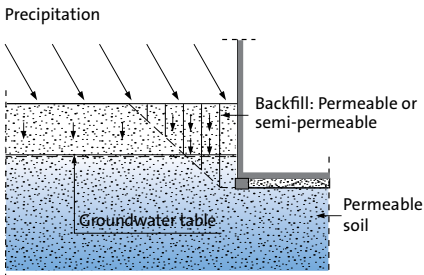

Draining in low-permeability soils with groundwater table higher than drainage level

Class 2:

Impermeable soil with groundwater level below drainage level. Here, storm water from within the backfill area should be drained. Seasonal variations in groundwater table are not predicted to increase to drainage level. Storm water or other surface water will soak vertically to the groundwater table.

Class 3:

Low-permeability soil with groundwater level above drainage level. Here, groundwater draining will protect the building from hydrostatic water pressure. Storm water or other surface water will soak vertically to the groundwater table. Storm water from within the backfill area and intact soil should be drained.

Class 4:

High-permeability soil with groundwater level above drainage level. Here, attempts to drain groundwater will result in very high drain water amounts. Furthermore, such attempts will lead to a general lowering of the groundwater table, which may damage surrounding constructions. In this case, groundwater draining cannot be carried out. Here, the building must be water tight, sufficiently anchored to avoid lift and reinforced to withstand hydrostatic water pressure. Storm water or other surface water will soak vertically to the groundwater table.

Drain water flow rate

The drain water flow rate should be estimated before the design of drainage system and sizing of pumps. Compared to rainwater flow rates, drain water flow rates are usually modest.

Walls:

Class 1: Typically not drained

Class 2: Water flow rate per sq. metre wall:
 $q = 0,01 - 0,03 \text{ l/sm}^2$

Class 3: Water flow rate per sq. metre wall:
 $q = 0,03 - 0,1 \text{ l/sm}^2$

Class 4: Typically not drained

Floors:

Class 3: Water flow rate per sq. metre floor:
 $q = 0,001 - 0,005 \text{ l/sm}^2$

Class 4: Typically not drained

Note:

Water flow rates per sq. metre wall or floor are estimated on the basis of climate conditions with moderate precipitation intensities, frequencies and duration. Drain water flow rates should always be based on national guidelines and legislation.

The drain water flow rate, Q_d is calculated from:

$$Q_d = A \cdot q \quad \text{where}$$

Q_d = Drain water flow rate (l/s)

A = Wall or floor area (m^2)

q = Water flow rate per sq. meter, wall or floor

EXAMPLE: CALCULATION OF DRAIN WATER FLOW RATE

A commercial building is in the design phase. Groundwater and soil conditions have been investigated and the building will need a drainage system around its perimeter and under the basement floor.

Building dimensions:

Basement height: 4 m

Basement length: 40 m

Basement width: 20 m

The building soil is impermeable and the groundwater table is higher than the drainage level, making this a class 3 building.

Drain water flow rate, $Q_d = A \cdot q$

$$\text{Walls: } 2 \cdot (20 \text{ m} + 40 \text{ m}) \cdot 4 \text{ m} \cdot 0,06 \text{ l/sm}^2 = 28,8 \text{ l/s}$$

$$\text{Floor: } 20 \text{ m} \cdot 40 \text{ m} \cdot 0,003 \text{ l/sm}^2 = 2,4 \text{ l/s}$$

$$\underline{\text{Drain water flow rate, } Q_d} = \underline{31,2 \text{ l/s}}$$

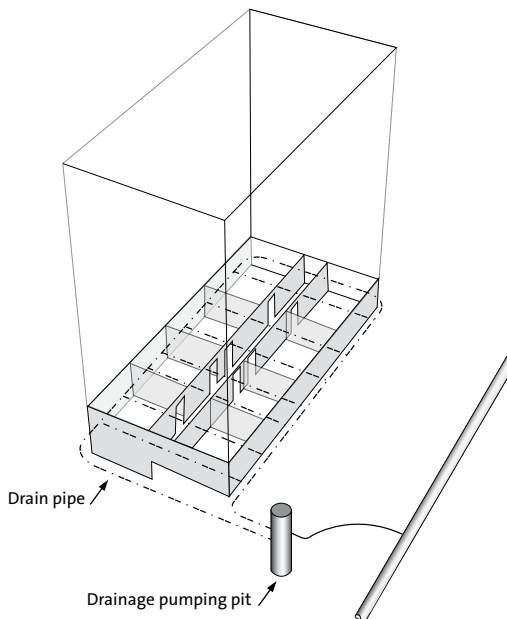

WASTEWATER PUMP SIZING

Pump head, H_p

The pump's discharge head, H_p should be equal to or greater than the total head in the system, H_{tot}

The total head is calculated as shown below:

$$H_{tot} = H_{geo} + H_v \quad \text{where}$$

$$H_v = H_{V,A} + H_{V,R} \quad \text{where}$$

H_{tot} = Total head (m)

H_{geo} = Static head (m)

H_v = Dynamic head losses (m)

$H_{V,A}$ = Head losses in valves and fittings etc. (m)

$H_{V,R}$ = Linear friction losses in discharge pipework (m)

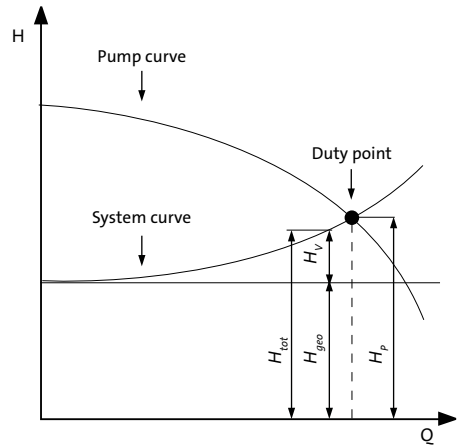

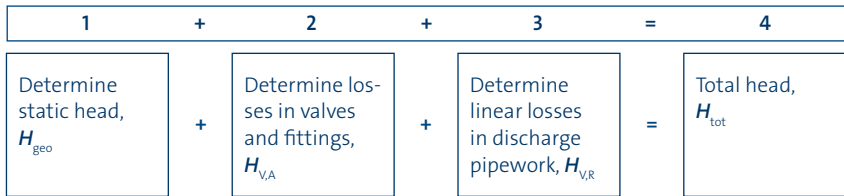
CALCULATION: PROCEDURE OF HEAD, H_{TOT} 

1. Static head, H_{geo}

Static head or geometric height describes the height difference the pump should lift the wastewater and is normally calculated as the difference between the pump's stop level and the height of the discharge pipe outlet. If a water backflow level is defined, this has to be taken into account. If the backflow level is higher than the discharge pipe outlet, the backflow level should be used for calculating static head.

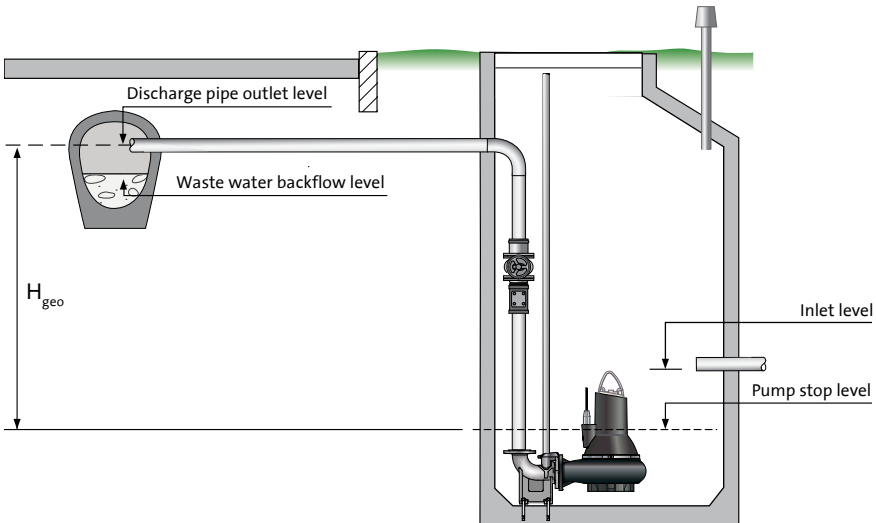

Wastewater backflow level is defined lower than discharge pipe outlet. Static head should be calculated up to the level of the discharge pipe outlet.

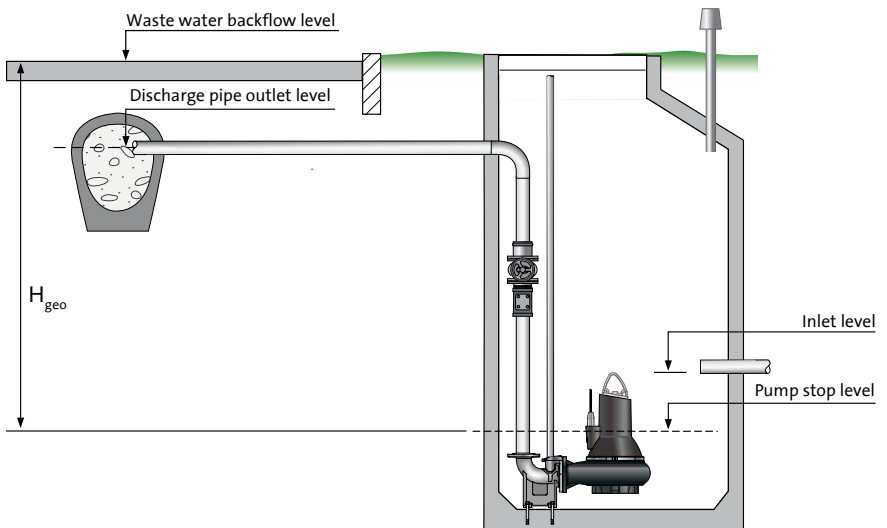

Here, the wastewater backflow is equal to street level and higher than discharge pipe outlet. Static head has to be calculated up to street level.

2. Losses in valves and fittings, $H_{V,A}$

Discharge pipe size should be determined on the basis of the desired pipe velocity. Generally, flow velocity should be no less than 0,7 m/s and no higher than 2,3 m/s. If velocity is lower than 0,7 m/s there is an increased risk of deposit build-up in the pipe, which can lead to clogging. The pipe velocity is calculated as shown:

$$v = \frac{Q}{A} \quad \text{where}$$

- v = Pipe velocity (m/s). Recommended between 0,7 – 2,3 m/s
- Q = Wastewater flow rate (m³/s)
- A = Internal pipe area (m²)

When the discharge pipe size has been selected, it is possible to calculate head losses in the discharge pipe system's valves and fittings using the following formula:

$$H_{V,A} = \sum_i \zeta_i \frac{V_i^2}{2g} \quad \text{where}$$

- (Zeta) = Resistance factor (Z) (-) from table.
- $H_{V,A}$ = Head losses in valves and fittings etc. (m)
- v = Velocity in valve or fitting (m/s)
- g = Gravitational constant (m/s²)

3. Linear friction losses in discharge pipe, $H_{V,R}$

The total pressure loss in the discharge pipe can now be determined:

$$H_{V,R} = H_{V,J} \cdot L_{V,i} \quad \text{where}$$

- $H_{V,R}$ = Linear friction loss in discharge pipe work (m)
- $H_{V,J}$ = Head loss as a function of flow rate, (-)
- $L_{V,i}$ = Pipe length, (m)

Type of resistance	Zeta value
Shut-off valve	0,5
Non-return valve	2,2
Bend 90	0,5
Bend 45	0,3
Free outflow	1,0
T-pieces 45	0,3 - 0,6
T-pieces 90	0,5 - 1,5
Increase in diameter	0,3

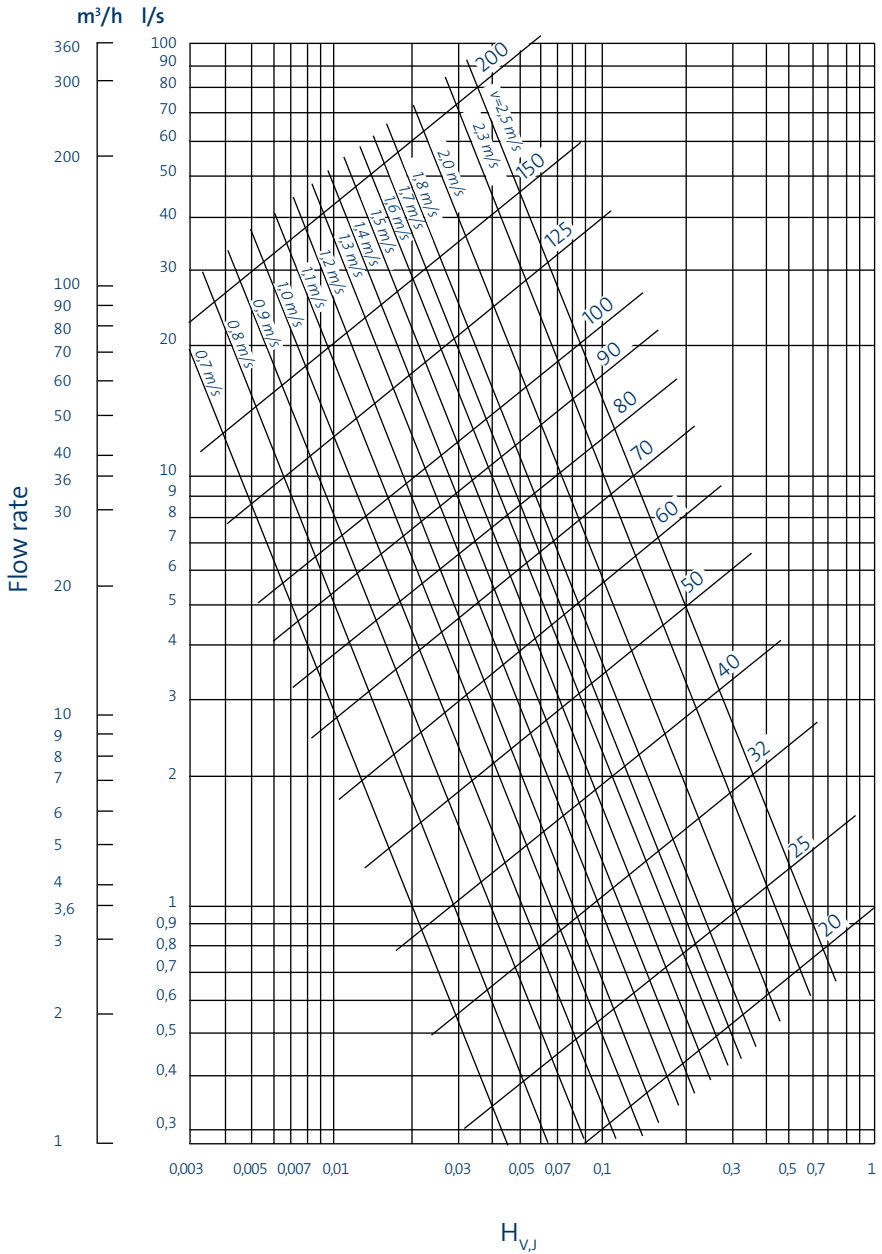

EXAMPLE: SIZING OF SUBMERGED WASTEWATER PUMPS, PAGE 1

Wastewater from an 80-room hotel building must be pumped to a sewage main in a nearby street. The wastewater flow rate has already been calculated:

$$Q_{\text{tot}} = Q_{\text{ww}} + Q_c + Q_p = 3,76 + 0 + 0 = 3,76 \text{ l/s}$$

Other data:

Street level	0,0 m
Discharge pipe inlet to sewer main	1,0 m below street level
Highest backflow level	2,0 m below street level
Wastewater inlet level	5,5 m below street level
Pump stop level	6,5 m below street level

Discharge pipe length: 75 m

1. Static head:

$H_{\text{geo}} = \text{Discharge pipe inlet level} - \text{pump stop level}$

$$H_{\text{geo}} = 6,5 \text{ m} - 1,0 \text{ m} = 5,5 \text{ m}$$

2. Losses in valves and fittings $H_{v,A}$:

The pipe velocity is calculated from: $v = \frac{Q}{A}$

A DN80 pipe with an internal diameter of 70 mm is chosen. The water velocity turns out to be within the acceptable range of 0,7 m/s to 2,3 m/s.

$$v = \frac{Q}{A} = \frac{Q}{\frac{\pi}{4} \cdot d_i^2} = \frac{3,76 \cdot 10^{-3}}{\frac{\pi}{4} \cdot 0,07^2} = 0,98 \text{ m/s}$$

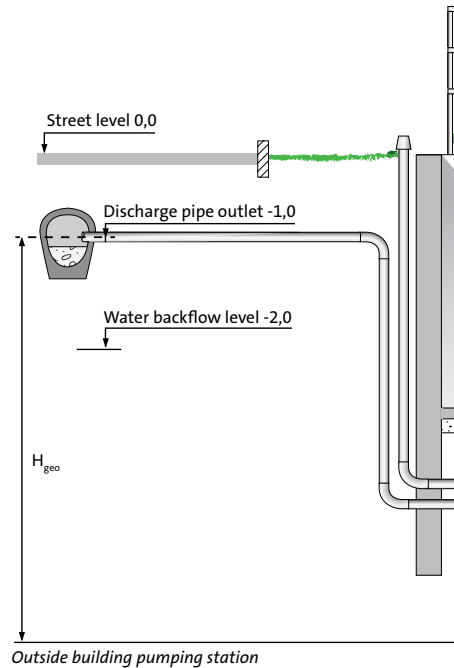

Resistance factors (Zeta) (-) for valves and fittings on discharge pipe are calculated:

Shut-off valve	1 · 0,5	= 0,5
Non-return valve	1 · 2,2	= 2,2
Bend 90	5 · 0,5	= 2,5
T-piece	1 · 1,5	= 1,5
Total (Zeta) value		= 6,7

Head losses in valves and fittings are calculated:

$$H_{V,A} = \sum_i \zeta_i \frac{V_i^2}{2g}$$

$$H_{V,A} = 6,7 \frac{0,98}{2 \cdot 9,81} = 0,33 \text{ m}$$

3. Linear friction losses in discharge pipe, $H_{V,R}$

The total pressure loss in the discharge pipe is determined:

$$H_{V,R} = H_v \cdot L_{v,i} = 0,020 \cdot 75 \text{ m} = 1,50 \text{ m}$$

Head, $H_{V,j}$ is found in the diagram.

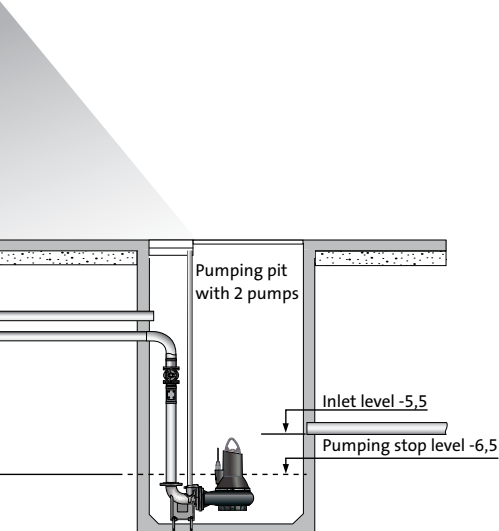
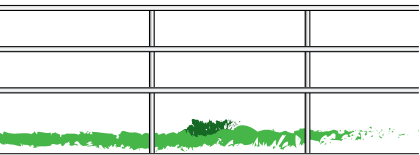

EXAMPLE: SIZING OF SUBMERGED WASTEWATER PUMPS, PAGE 2

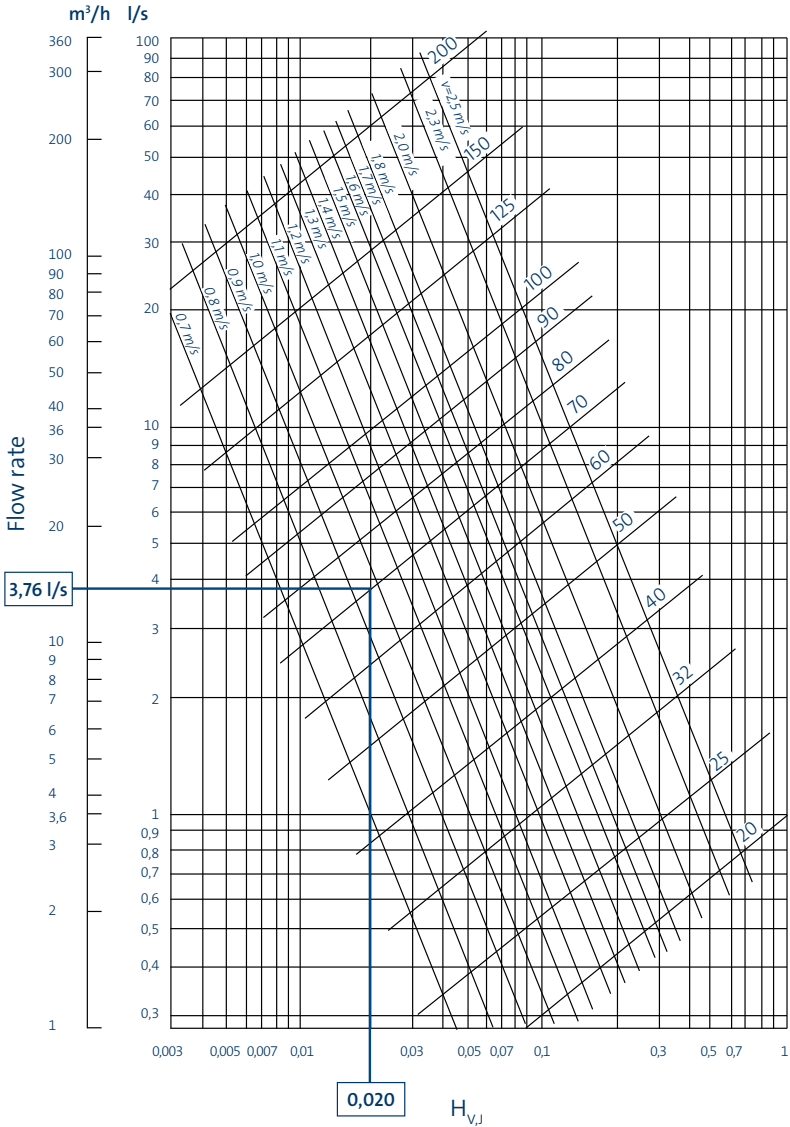

4. Discharge head, H_p

The pump's discharge head, H_p , should be equal to or greater than the total head in the system, H_{tot} . The total head is calculated below:

$$H_{tot} = H_{geo} + H_v \quad \text{where} \quad H_v = H_{v,A} + H_{v,R}$$

$$H_{tot} = H_{geo} + H_{v,A} + H_{v,R}$$

$$H_{tot} = 5,5 \text{ m} + 0,33 \text{ m} + 1,50 \text{ m} = 7,33 \text{ m}$$

The right pumps are found with WebCAPS.

Flow, static head (geometric head) and friction losses are used as input in WebCAPS:

Flow, Q_{tot}	=	3,76 l/s
Static head, H_{geo}	=	5,5 m
Friction losses: $H_{v,A} + H_{v,R}$	=	1,83 m

The pumps

In this installation, a two-pump solution is selected to meet the 100% redundancy requirement. Both pumps will be sized for full capacity, with one pump running at a time in an alternating pattern.

WebCAPS' 2nd choice is SL1.80.80.15.4.50D.B. The pumps have free passages of 80 mm and 80 mm outlets.

The pumps are slightly oversized for the duty point with a flow of 4,55 l/s (+21%) and a head of 8,17 m (+11%).

EXAMPLE: SIZING OF SUBMERGED WASTEWATER PUMPS, PAGE 3

GRUNDFOS WEBCAPS

Home Catalogue Literature Service **Sizing** Replacements

Wastewater > Commercial buildings > Sewage > Sewage

Your requirements

Selected Area: Commercial buildings

Installation Type: Sewage

Submersible pump with autocoupling system

Total number of pumps: 2

Of these: number of standby pumps: 1

Cooling jacket required:

Discharge Flow (Q): 3.75 l/s

Geodetic Head: 5.5 m

Pipe friction losses: 1.83 m

Variable speed: No

Allowed undersize: 2 %

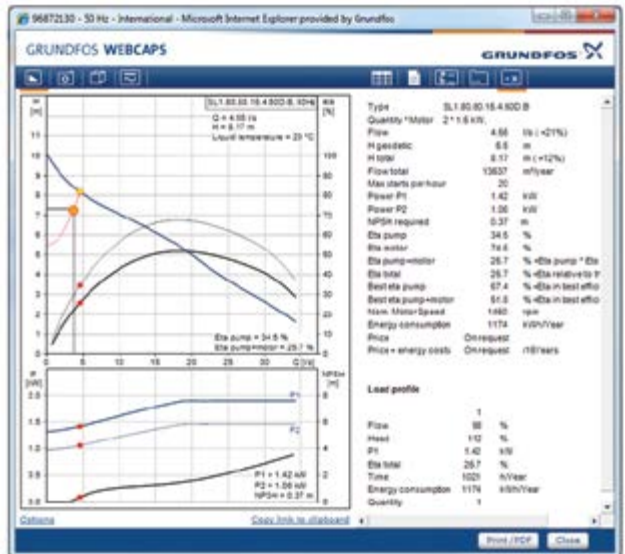

EXAMPLE: SIZING OF A LIFTING STATION, PAGE 1

Wastewater from an apartment building has to be pumped to the sewage main.
This time, we will use a lifting station for the job.

Pump stop level	5,0 m below ground floor level
Discharge pipe inlet to sewer main	1,0 m below ground floor level
Highest backflow level	0,5 m below ground floor level
Street level	0,5 m below ground floor level

Discharge pipe length: 139 m

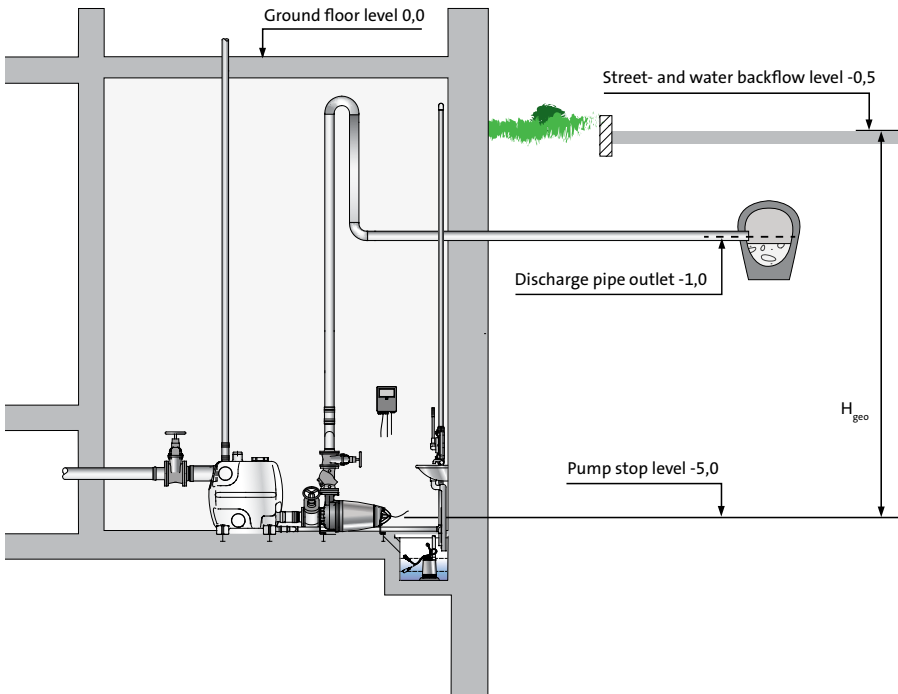

Lifting stat in a building basement

EXAMPLE: SIZING OF A LIFTING STATION, PAGE 2

1. Maximum hourly inflow volume, $V_{\max, h}$

The wastewater appearance from domestic sanitary appliances varies greatly over the course of a day, with studies showing that morning is generally the peak period. To determine the required tank size, the hourly maximum expected wastewater volume $V_{\max, h}$ has to be calculated for the hour of the day (or week) where flow is at its highest. For an apartment building, this is typically in the morning hours when residents are taking showers and doing their morning toilette. In this example, the apartments are on average occupied by two persons. The total wastewater volume, $V_{\max, h}$ is calculated below.

Average apartment with 2 persons	Flow, l/min	Volume, l	Duration, min.	Usages, h-1	Total flow, l/h
Wash basin	10		4	2	80
Shower	10		5	2	100
Kitchen zink		15		1	15
Dishwasher		20		1	15
Washing machine, 6 kg		60		1	30
WC, 4 l flush		4		2	8
WC, 6 l flush		6		2	12
Total water volume within an hour					260

Scheme for determining the maximum wastewater volume within a single hour, $V_{\max, h}$

There are 50 apartments in the building, making the total wastewater volume:

$$\Sigma V_{\max, h} = 50 \cdot 260 \text{ l/h} = 13.000 \text{ l/h}$$

2. First selection of lifting station

Lifting stations are typically made for intermittent operation whereby they run a certain number of pump and pause cycles every hour. The maximum start/stops of a lifting station pump is 60 per h. Using this simple rule, the lifting station's total drainage capacity Q_{\max} is calculated by multiplying the number of hourly start/stops with the efficient tank volume. Q_{\max} should exceed $\Sigma V_{\max, h}$

$$Q_{\max, h} = \text{Eff. tank vol.} \cdot 60$$

In this case, a Multilift type MD1/V is preferred. With one tank, it has an efficient tank volume of 240 l. Making 60 start/stops per hour, the total drainage capacity of this Multilift MD1/V is:

$$Q_{\max, h} = 240 \text{ l} \cdot 60 \text{ h}^{-1} = 14.400 \text{ l/h which exceeds}$$

$$V_{\max, h} = 13.000 \text{ l/h}$$

Type	Number of tanks	Eff.tank vol.
Multilift MSS	1	28
Multilift M	1	62
Multilift MOG	1	50
Multilift MD	1	86
Multilift MLD	1	190
Multilift MDG	1	50
Multilift MD1/V+SL	1	240
Multilift MD1/V+SL	2	480
Multilift MD1/V+SL	3	720

Efficient Multilift tank volumes

3. Determination of the wastewater flow, Q_{ww} :

To determine losses in valves and fittings and check water velocity in the discharge pipe, the wastewater flow rate according to EN 12056-2 must be calculated.

According to EN12050-2 System 2	DU l/s	Amount	Total l/s
Wash basin	0,3	2	0,6
Shower	0,4	2	0,8
Kitchen sink	0,6	1	0,6
Dishwasher	0,6	1	0,6
Washing machine, 6 kg	0,6	1	0,6
WC	1,8	2	3,6
Total flow			6,8

Each lifting station will service 50 apartments (each with DU of 7,4 l/s), which makes for a Q_{ww} of:

$$Q_{ww} = K \sqrt{\sum DU} = 0,5 \sqrt{6,8 \cdot 50} = 9,22 \text{ l/s}$$

Frequency factor of 0,5 is chosen according to table on page 22.

4. Losses in valves and fittings, $H_{v,A}$:

The pipe velocity is calculated from: $v = \frac{Q}{A}$

The water velocity turns out to be within the acceptable range of 0,7 m/s to 2,3 m/s. A pipe with an internal diameter of 90 mm is chosen.

$$Q = 9,22 \cdot 10^{-3} \text{ m}^3/\text{s}$$

$$v = \frac{Q}{A} = \frac{Q}{\frac{\pi}{4} \cdot d_i^2} = \frac{9,22 \cdot 10^{-3}}{\frac{\pi}{4} \cdot 0,09^2} = 1,45 \text{ m/s}$$

Resistance factors (Zeta) (-) for valves and fittings on the discharge pipe are calculated:

Shut-off valve	$1 \cdot 0,5 = 0,5$
Non-return valve	$1 \cdot 2,2 = 2,2$
Bend 90	$5 \cdot 0,5 = 2,5$
T-piece	$1 \cdot 1,0 = 1,0$
Total (Zeta) value	= 6,2

Head losses in valves and fittings are calculated:

$$H_{v,A} = \sum_i \zeta_i \frac{V_i^2}{2g}$$

$$H_{v,A} = 6,2 \frac{1,45^2}{2 \cdot 9,81} = 0,7 \text{ m}$$

5. Linear friction losses in discharge pipe, $H_{V,R}$

The total pressure loss in the discharge pipe is determined:

$$H_{V,R} = H_{V,i} \cdot L_{V,i} = 0,031 \cdot 139 \text{ m} = 4,3 \text{ m}$$

Head, $H_{V,i}$ is found in the diagram.

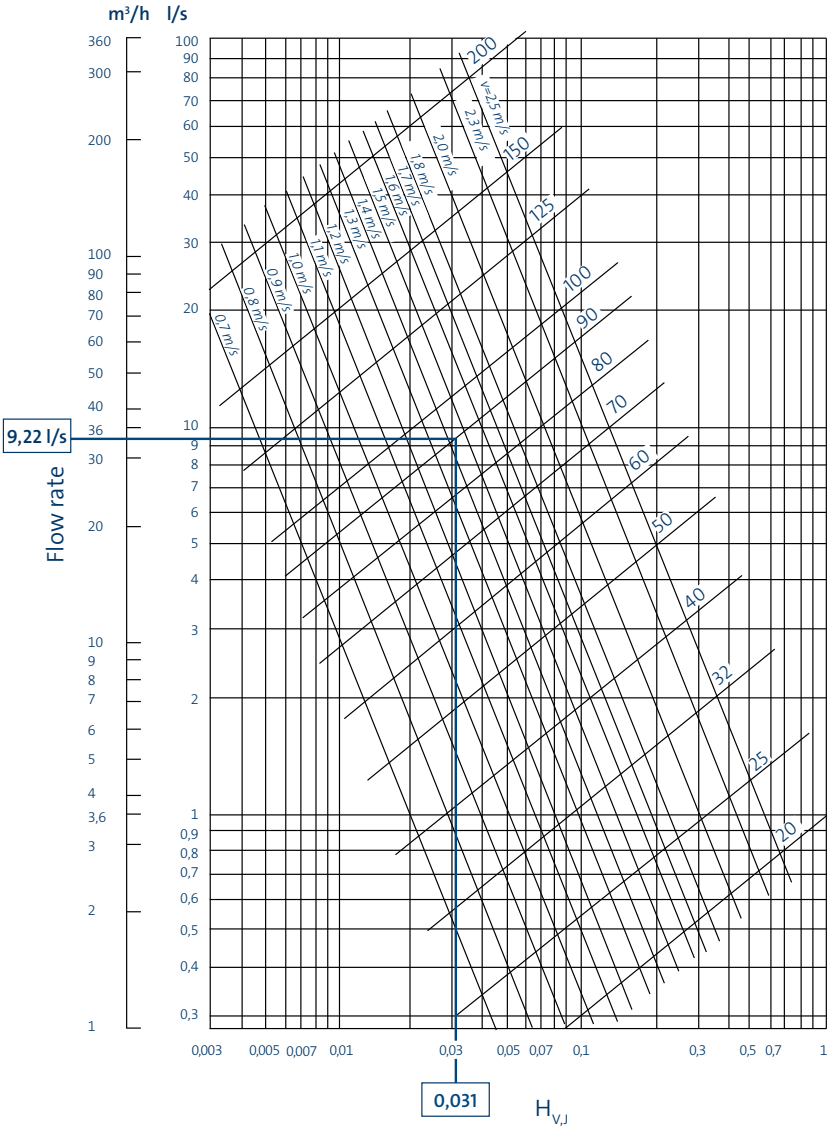

EXAMPLE: SIZING OF A LIFTING STATION, PAGE 5

6. Discharge head, H_p

The pump discharge head, H_p should be equal to or greater than the total head in the system,

$$H_{tot}$$

The total head is calculated as shown below.

$$H_{tot} = H_{geo} + H_v \quad \text{where} \quad HV = H_{V,A} + H_{V,R}$$

$$H_{tot} = H_{geo} + H_{V,A} + H_{V,R} = 4,5 \text{ m} + 0,7 \text{ m} + 4,3 \text{ m} = 9,5 \text{ m}$$

7. Final selection of lifting station

Since 100% redundancy is required in this installation, a two-pump solution is selected where both pumps are sized for full capacity and set for alternating operation with only one pump running at a time.

Pumps for the lifting station solution are selected using the diagram below or WebCAPS.

A one-tank lifting station MD1.80.80.22.4 is selected.



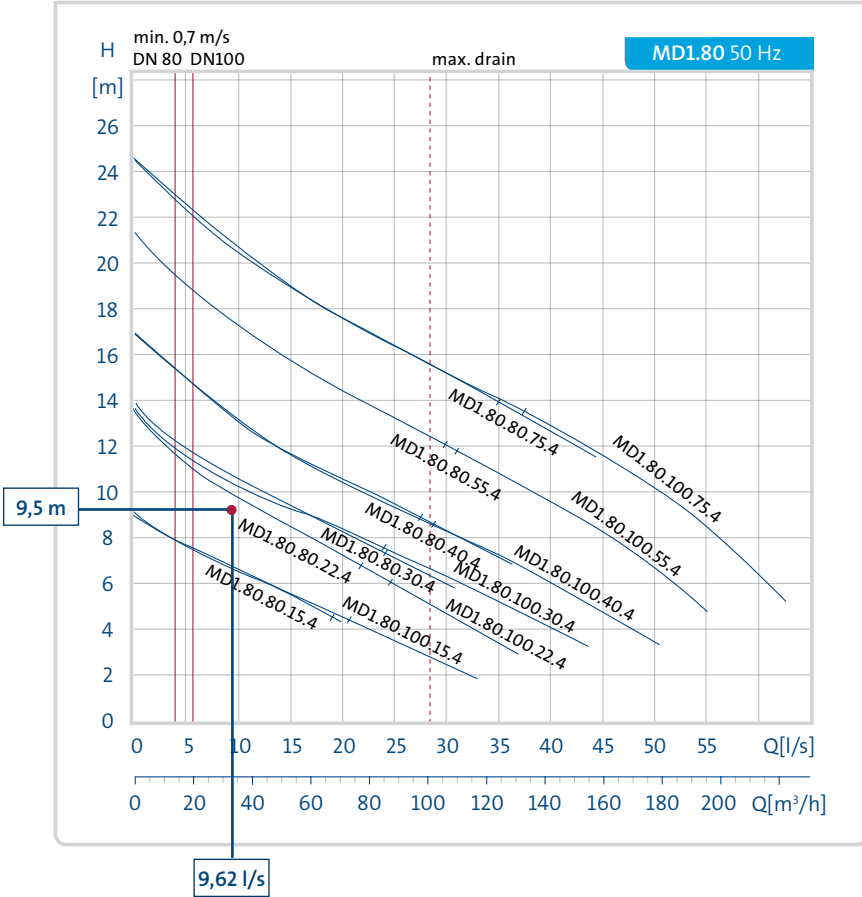

IMPELLER TYPES

S-tube impeller

The S-tube offers greater hydraulic efficiency than other types of wastewater impeller and is also more resistant to clogging. The S-tube impeller has an uncompromised free passage all the way from inlet to outlet, which gives the impeller its superior anti-clogging characteristic. The S-tube impeller also offers a superior solution to jamming – another well-known wastewater pump problem. Jamming occurs when dirt and long fibres fill up the cavity between the impeller and the pump housing. The S-tube impeller is designed with a cutter system that separates fibres into small parts and a pulse flush system that flushes fibres away from the gap between impeller and pump housing. The small fibres are flushed back into the impeller inlet and pumped away. The S-tube impeller is designed for pumping of both media without impurities and wastewater with high content of fibres and solid objects such as faeces.

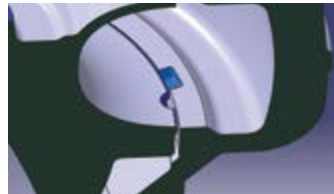
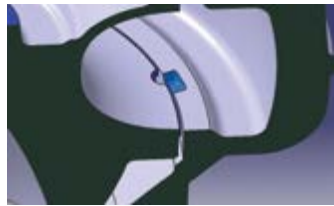

The simple but efficient pulse-flushing system makes eight pulses per revolution



S-tube impeller.

Characteristics:

- Free passage allows for use in wastewater with faeces and other large solids
- High efficiency impeller. Up to more than 83 % efficiency in best point
- High and flat efficiency curve. Efficiency >75 % in a wide flow area
- High resistance to clogging and jamming
- Well-suited for wastewater with fibres and large solid objects
- Less vibration compared to other impellers

Wastewater types:

- Drainage water
- Grey water
- Black water
- Storm water

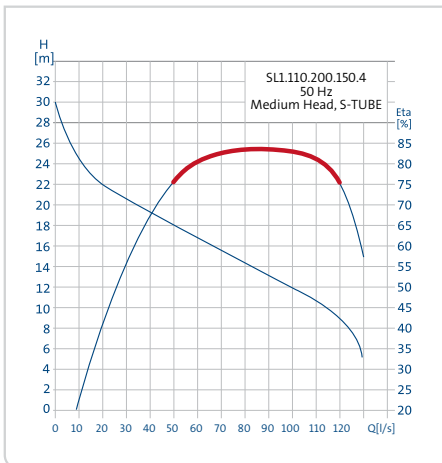

Example of an S-tube efficiency curve. The efficiency is more than 75 % in a wide flow area.

Single-channel impeller

The single-channel impeller is designed for high-efficiency pumping of both media without impurities and water with high content of objects such as faeces.

The impeller has one media passage route, which protects against clogging. Integrated counterweights balance the asymmetric impeller.

Highest attainable efficiency is 70-75 %.

Characteristics:

- Free passage allows for use in wastewater with faeces and other large solids
- High-efficiency impeller. Up to 75 %
- Medium safety against clogging

Wastewater types:

- Drainage water
- Grey water
- Black water
- Storm water

Vortex impeller

The Vortex impeller creates a strong vortex in the open pump casing. The impeller is situated outside the main liquid flow, making the pumping action indirect. Vortex impeller pumps inherently offer excellent protection against clogging and are – unlike pumps with single-channel impellers – smooth-running and highly resistant to fibres in the media. The highest attainable efficiency for Vortex impellers is around 50 %.



Single-channel impeller



Vortex impeller. The vane winglets prevent the formation of secondary eddies over the vane edges, improving pump efficiency.

Characteristics:

- Free passage allows for use in all kinds of wastewater
- Medium-efficiency impeller. Efficiency of 50 %
- High protection against clogging
- No risk of jamming
- Well-suited for wastewater with fibres and large solid objects

Wastewater types:

- Grey water
- Black water

Grinders

Grinder pumps are suitable for installations with relatively small amounts of sewage and high head. Their ability to supply high head and cut up sewage solids efficiently make them the right choice for pressurised wastewater systems.

The grinder pump shreds solids into small fragments of around 10 mm, which makes it possible to transport media in small pressure pipes over long distances. Grinders should not be used for storm water with sand content since the shredder is very susceptible to wear.

Characteristics:

- Shreds all kinds of solids: diapers, rubber gloves, towels, plastic toys, faeces etc.
- Sensitive to sand in the media
- Not sensitive to clogging

Wastewater types:

- Grey water
- Black water



A grinder pump with its cutting knife of hardened stainless steel

be think innovate



VISIT US ONLINE

For more information on Grundfos Commercial Building Services and our services, please visit www.thinkingbuildings.com

Here, you can read all about our products or use our online tools, including the timesaving Quick Pump Selection tool.

GRUNDFOS Holding A/S
Poul Due Jensens Vej 7
DK-8850 Bjerringbro
Tel: +45 87 50 14 00
www.grundfos.com

GRUNDFOS 

9841767/013/BD MARKETING/11239-D&I

The name Grundfos, the Grundfos logo, and be think innovate are registered trademarks owned by Grundfos Holding A/S or Grundfos A/S, Denmark. All rights reserved worldwide.